

# TINKO

## Planter

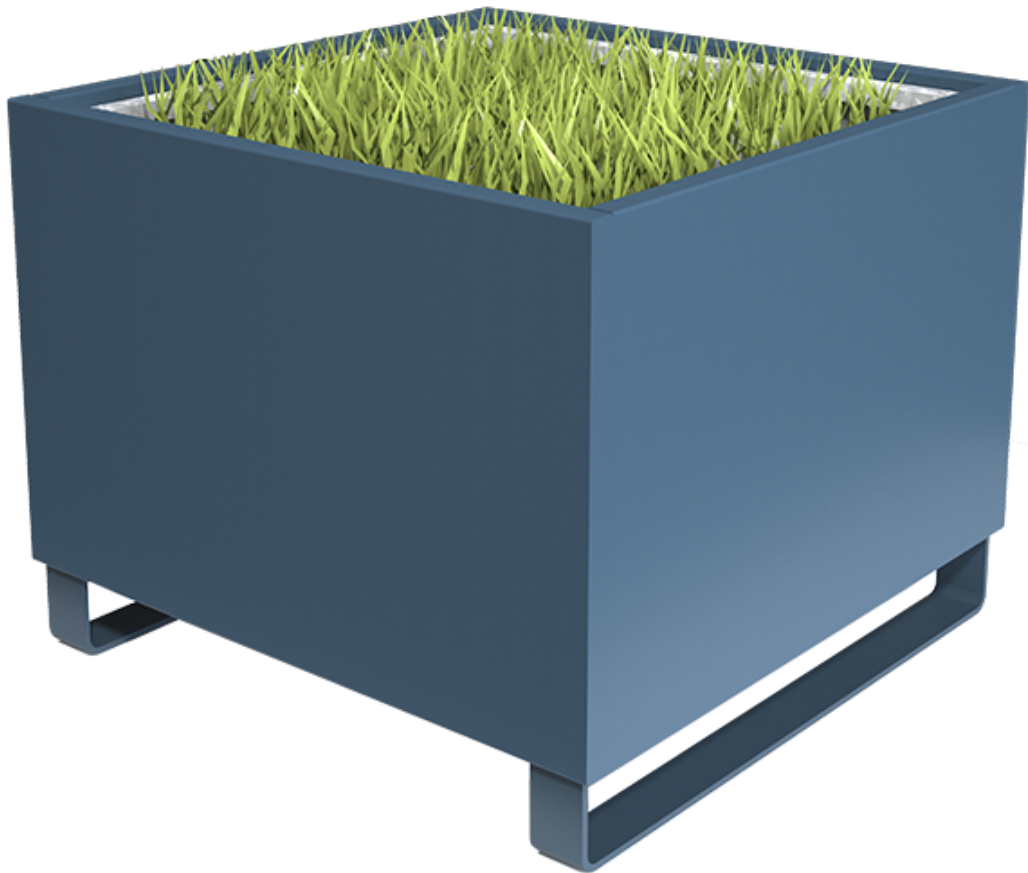



**The Tinko planter is available in two sizes, it can be supplied with an irrigation system. Maintenance-free thanks to our four-phase anti-corrosion treatment for steel. It can be used alone or in groups and combines perfectly with furniture from the Tinko range.**

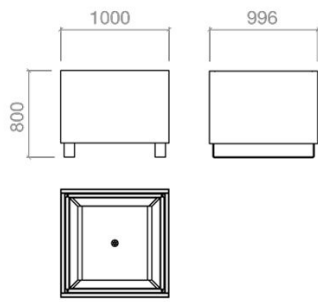

TIJA00MN

# Materials

## Virtually no maintenance

Todos los componentes están diseñados para permanecer en el exterior durante años con un nivel mínimo de mantenimiento, preparados para resistir incluso a las condiciones más extremas.

## Atlantic sea proof steel

Design furniture from Joma is designed for use in challenging and harsh environments.

All steel components are Joma Marine™ treated and come with a lifetime warranty against rust.

This process was developed to ensure a high-quality finish that complies with the strict requirements of Corrosion Class C5-M (EN ISO 12944), which enables our products to remain outdoors for several decades. All screws and fastenings are supplied in stainless steel.

First, comprehensive cleaning and pre-treatment, involving many stages, are carried out. Components are dipped in a series of immersion tanks, filled with degreasing agents, purified water and activators. Then, it's time for the cathodic electrodeposition, which consists of a process of immersion painting, based on the displacement of charged particles within an electric field (paint tank) towards the opposite sign pole (metal part to be painted). So, by applying an electric potential difference, the paint molecules are deposited on the piece (cathode) evenly. This process produces an antioxidant coating that allows our products to remain outdoors for several decades. It is carried out in accordance with the strict specific environmental requirements in ISO 12944.

El recubrimiento en polvo es completamente libre de disolventes y se aplica electrostáticamente a través de boquillas automáticas. El polvo se polimeriza en un horno automatizado para dar al producto su aspecto final y garantía.

The powder coating is completely solvent-free and is applied electrostatically through advanced nozzles. The powder is then melted in an automated curing oven to give the product its final appearance and warranty. This process was developed to ensure a high-quality finish that complies with the strict requirements of Corrosion Class C5-M (EN ISO

12944). This treatment far exceeds the corrosion tests Saline Fog Chamber (UNE-EN ISO 9227) and the European Standard UNE EN 13724.

<b>Class (ISO 12944)</b>	<b>Examples</b>
C1	Edificios calefactados
C2	Al aire libre en áreas interiores o en almacenes donde puede producirse condensación.
C3	Al aire libre en climas costeros con poco contenido de sal o en interiores en instalaciones de producción con altos niveles de humedad.
C4	Al aire libre en climas costeros con contenido moderado de sal o en piscinas cubiertas.
C5-I	Al aire libre en climas costeros con alto contenido de sal.
C5-M	Al aire libre en climas costeros con alto contenido de sal, alto niveles de humedad y corrosión atmosférica agresiva.

## Treatment in 4 phases

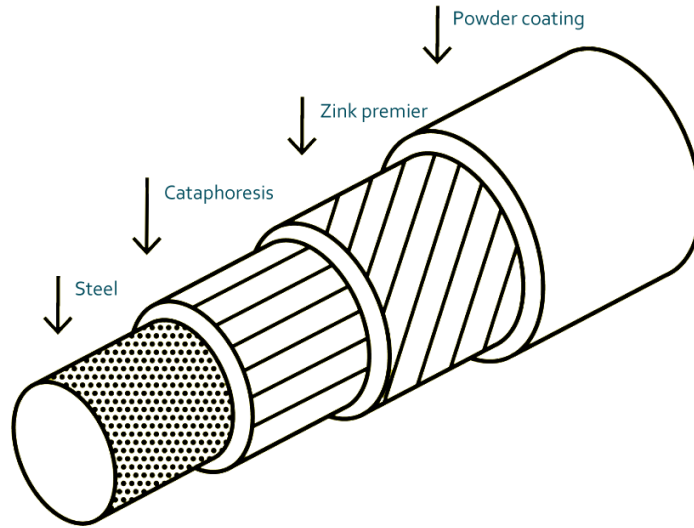

## Green thermowood

Our furniture uses Lunawood thermotreated wood with PEFC certificate and NordicSwan eco-label, manufactured naturally without toxic products. Special for outdoors, stands a class 2 durability and it has an expected useful life of more than 30 years if we consider the deterioration resistance (BRE).

For the most extreme cases, we provide Accoya acetylated wood, also with a PEFC certificate and NordicSwan eco-label. Its outdoor performance is unbeatable, reaching class 1 durability and a lifetime warranty\*

<b>Class</b>	<b>Madera</b>
1	<b>Accoya</b>
2	<b>Lunawood</b>
3	Cedro
4	Pino silvestre

\* Durability class 2 woods are suitable for above-ground exterior applications without the need for additional treatment.

\* Both must receive surface treatment before or immediately after installation if you want to preserve their precious brown tone. To preserve the color of the surface, it is possible to treat the boards with pigmented or stained wood oil, wax, paint or varnish, or wood protection stain, which contains a UV filter. The surface treatment can be applied before or immediately after installation using only a thin layer.

## Laminated panel

We use duromer high pressure laminate manufactured in accordance with EN-438-6 type EDF. Extremely resistant to fading, scratches and dents, making it ideal for outdoors where a low maintenance finish and long term durability are required. We offer a lifetime warranty with no color loss.

## Concrete

We use high quality architectural concrete HA40 B12 IIIa Qb SR resistant to aggressive environments, gray / white / black in color, with a fine pickled finish, waterproofed and with surface protection against stains and antifunguses according to EN 13198. We offer a lifetime guarantee. The SR compound, being less porous, becomes more resistant to moisture and mold. It comes with a lifetime warranty.